

Systemy **KOVÁNÍ POSUVNÝCH BRAN A VRAT**

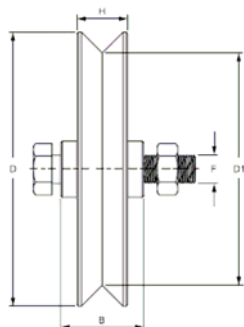

	D	D1	B	H	F	Kg	lož.
VKV 90	90	75	34	20	12	170	1
VKV 140	140	119	44	30	14	400	2

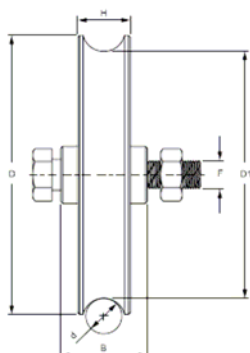

	D	D1	d	B	H	Kg	lož.
VKO 90	90	73,5	16	34	21	170	1
VKO 140	140	120	20	44	30	500	2

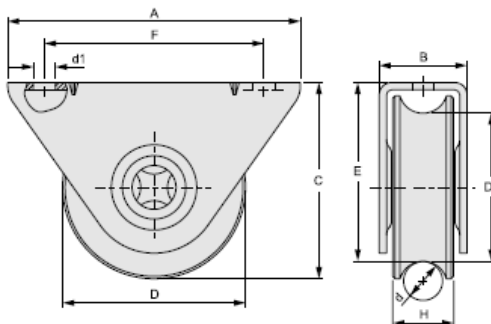

	D	D1	d	A	B	C	E	d1	F	H	Kg	lož.
VKOD 75	75	60	16	120	36	80	74	8,5	90	25	200	1
	D	D1		A	B	C	E	d1	F	H	Kg	lož.
VKVD 75	75	60		120	36	80	74	8,5	90	25	200	1

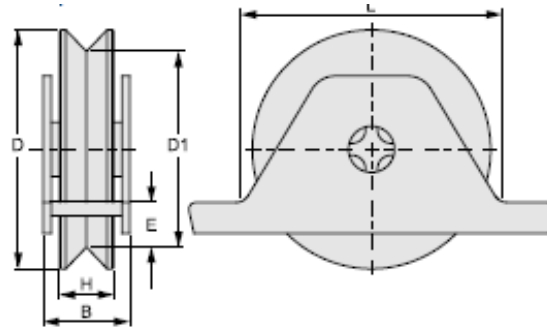

	D	D1	B	H	E	L	Kg	lož.
VKVDN 75	75	65	29	18	15	85	180	1

	D	D1	d	B	H	E	L	Kg	lož.
VKODN 75	75	60	16	29	21	15	85	200	1

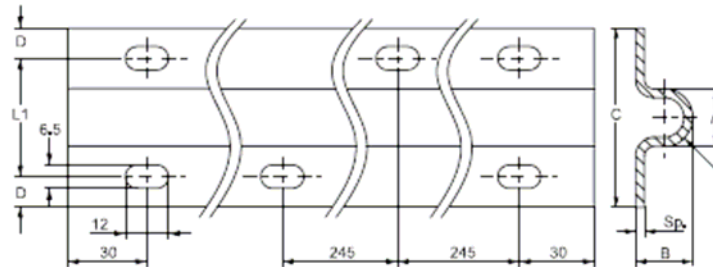

	A	B	C	D	L1	R	Sp	L(m)
KO 16	16	16	50	8,5	33	8	3	6

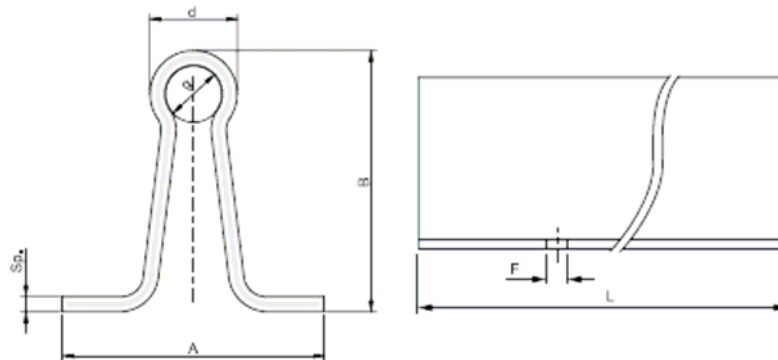

	A	B	d	Sp	L(m)
KO 16 B	50	50	16	3	6